



深圳市华百年电子有限公司

SHENZHEN HBY ELECTRONICS CO., LTD.

规格书specification

产品名称 Product Name	ISDN 语音分离器 ISDN SPLITTER		
产品型号 Product Model	YXSP307B		
			
	制作 DRAWN UP	审核 CHECKED	批准 APPROVED
姓名 NAME			
日期 DATE			

	<p style="text-align: center;">产品规格书 Product Specification</p>	<p style="text-align: center;">Edition: 0A</p>	<p style="text-align: center;">Page: 1 / 7</p>
<p>产品型号 Product Model</p>	<p>YXSP307B</p>		

CONTENTS

1	Mechanical characteristics	2
1.1	Housing	2
1.2	Silkscreen	3
1.3	RJ11 (double sockets)	3
1.4	PCB	4
2	Product structure	4
3	Electrical performance	5
3.1	Circuit schematic	5
3.2	Circuit layout	5
3.3	Electrical specification	6
4	Packing	7
4.1	SPLITTER packing: PVC polybag	7
4.2	Place(See picture)	7
4.3	Outer Packing	7

	<p style="text-align: center;">产品规格书 Product Specification</p>	<p style="text-align: center;">Edition: 0A</p>	<p style="text-align: center;">Page: 2 / 7</p>
<p>产品型号 Product Model</p>	<p>YXSP307B</p>		

1 Mechanical characteristics

1.1 Housing

- Housing size (MM) -see picture (50*45*24)

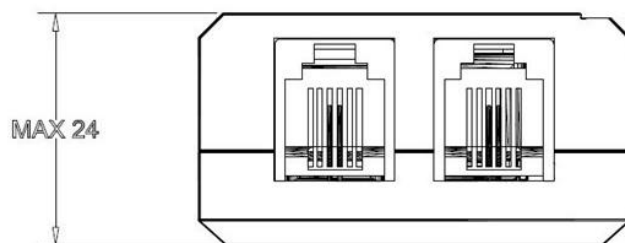
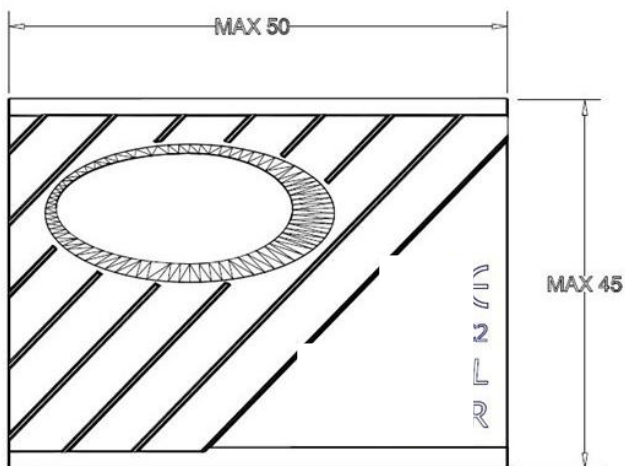

- Material: ABS
- Color: RAL



RAL

	<p style="text-align: center;">产品规格书 Product Specification</p>	<p style="text-align: center;">Edition: 0A</p>	<p style="text-align: center;">Page: 3 / 7</p>
<p>产品型号 Product Model</p>	<p>YXSP307B</p>		

1.2 Silkscreen

- Color: Blue
- Font size (MM) CE=5±0.1, AS-GC2=2±0.1, ADSL=35±0.1, SPLITTER=35±0.1
- Font : Tahoma
- Location as picture



1.3 RJ11 (double sockets)

- Material:HIPS
- Color: black
- 6P2C
- Gold plated:FU

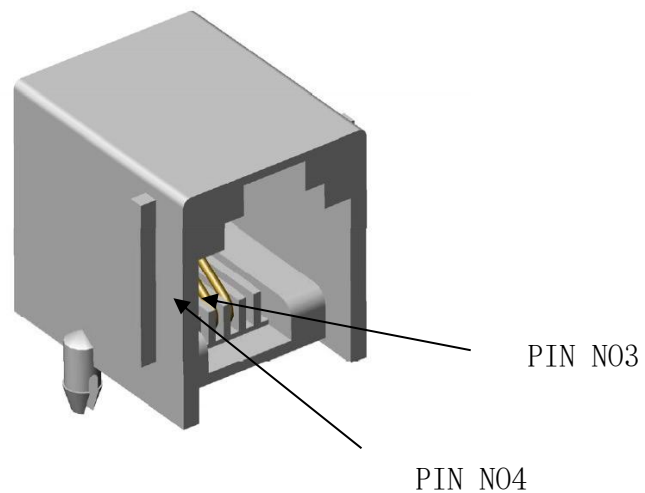



1.4 PCB

- Material:
- Model: :ISDN
- Number of layers: single sided board
- Dimension (mm) -see picture
- Thickness: : 1.6mm±0.1

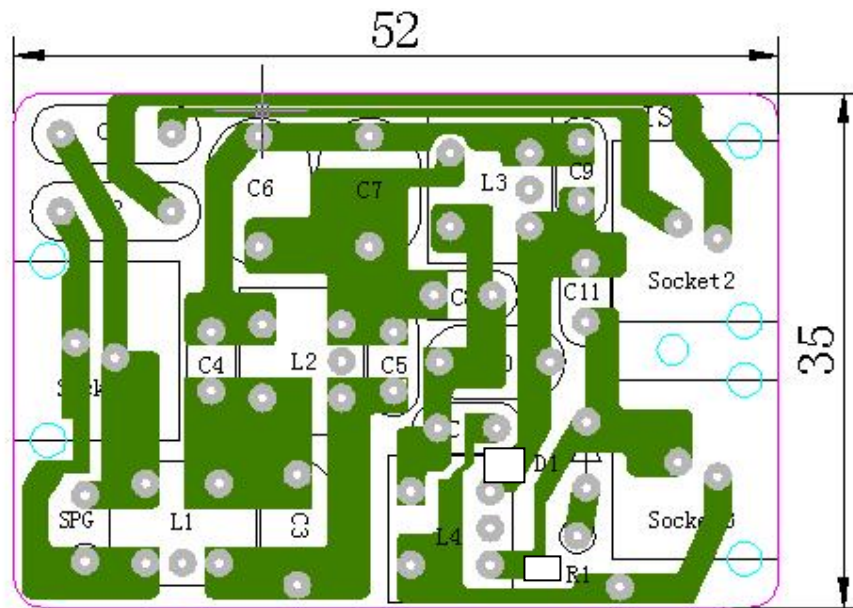

2 Product structure

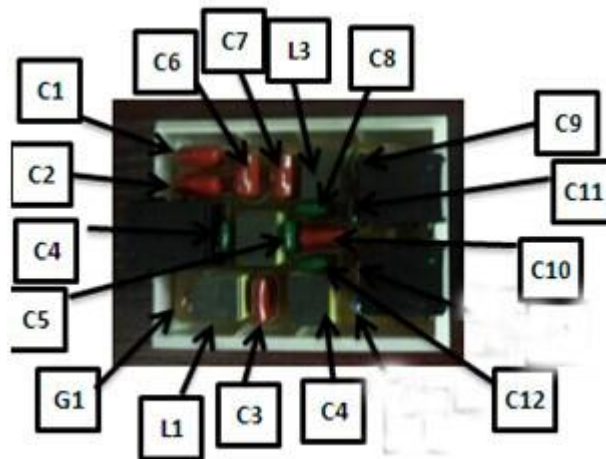



3 Electrical performance

3.1 Circuit schematic

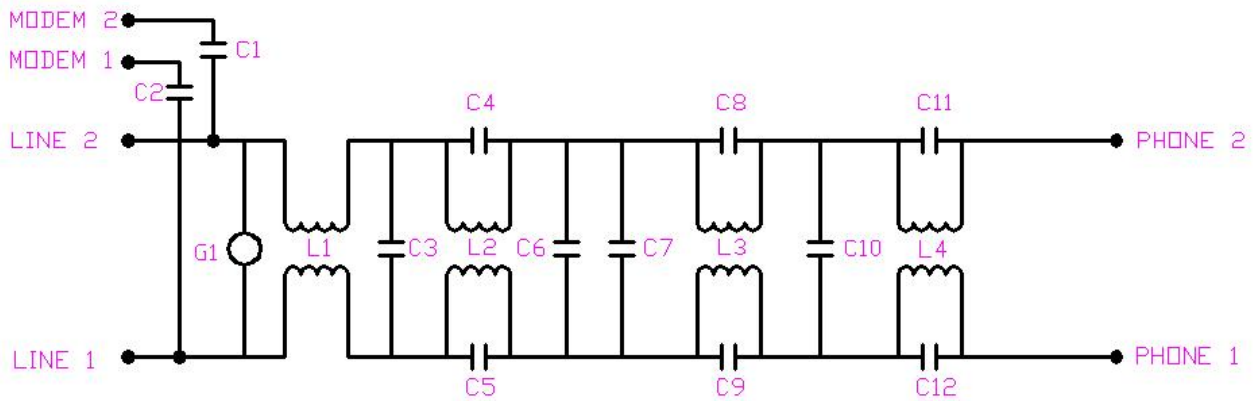

3.2 Circuit layout

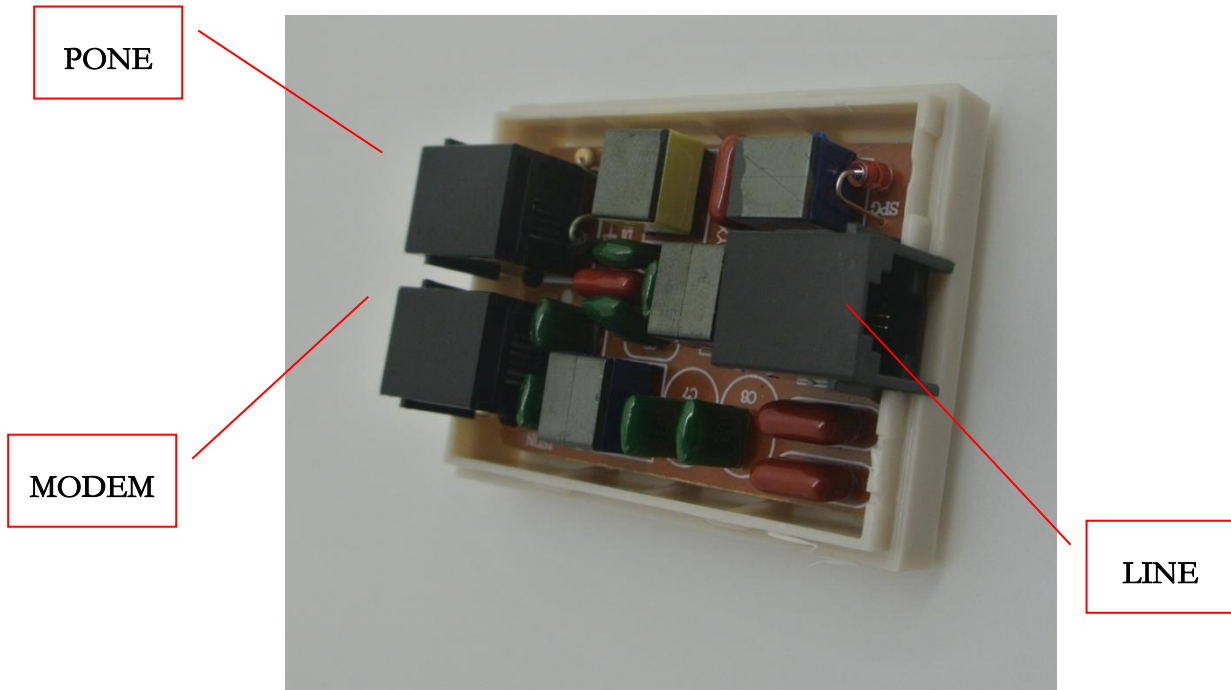



3.3 Electrical specification

POST PORT IMPEDANCE		Zr:135ohm(150 ohms *)
Modem impedance	32 kHz to 2208K Hz	100 Ω
ISDN Insertion loss	1.0KHz-40KHz	-0.8dB MAX
	1.0KHz-60KHz*	-1.2dB MAX
	40KHz-80KHz	-2.0dB MAX
	60KHz-80KHz*	-2.0dB MAX
Return loss	1KHz--40KHz	>16dB
	1KHz--60KHz*	>16dB
	40KHz--80KHz	>14dB
	60KHz--80KHz*	>14dB
DC resistance		<12.5 Ω
Insulation resistance	between A wire and B wire shall	>5MΩ
ISDN Delay distortion	1.0kHz-80KHz	< 20 usec
POTS Delay distortion	200Hz-4kHz	< 200usec
XDSL Attenuation	138KHz--150KHz	>55dB
	150KHz--1104KHz	>65dB
	1104KHz--12MHz	>55dB
Unbalance About Earth Voice band	300Hz--30KHz	>40dB
	30KHz--1104KHz	(ETSITR101952-1-3item6.5)
	1104kHz--5000kHz	>46dB

	<p style="text-align: center;">产品规格书 Product Specification</p>	<p style="text-align: center;">Edition: OA</p>	<p style="text-align: center;">Page: 7 / 7</p>
<p style="text-align: center;">产品型号 Product Model</p>	<p style="text-align: center;">YXSP307B</p>		

4 Packing

4.1 SPLITTER packing: PVC polybag



4.2 Place(See picture)

Horizontal 4PCS

Vertical 8PCS

Total 8 layers

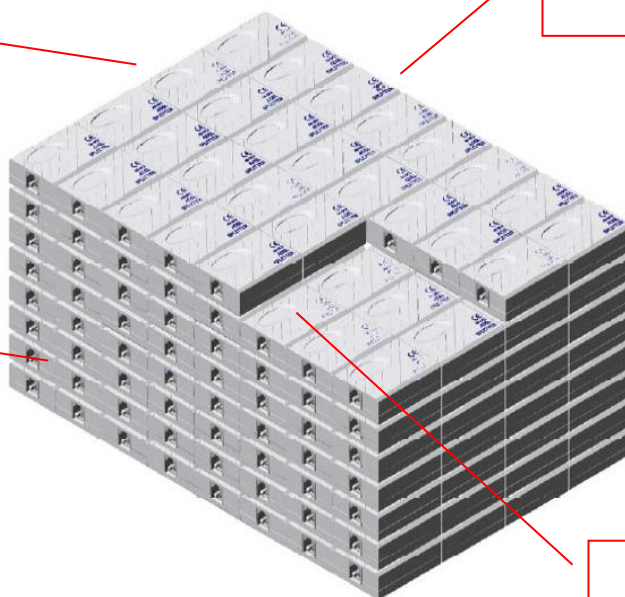

Less 6PCS

4.3 Outer Packing

- Material:K8K
- Dimension (CM) :38.5*28.5*23

	<p style="text-align: center;">产品规格书 Product Specification</p>	<p style="text-align: center;">Edition: 0A</p>	<p style="text-align: center;">Page: 8 / 7</p>
<p style="text-align: center;">产品型号 Product Model</p>	<p style="text-align: center;">YXSP307B</p>		

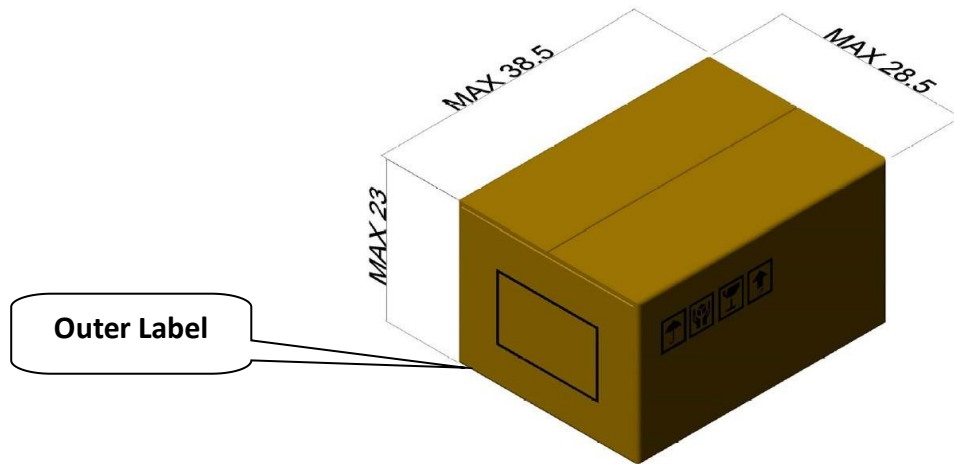

- Four small carton in a outer carton
- QTY:250
- N.W.:8.5
- G.W.:9.5